

SC

Mast climbing work platform **Monster SC8000**

Scanclimber SC8000 is the right tool when the capacity and platform size of other mast climbing work platforms are not sufficient. It is a perfect choice for heavy-duty facade work, and for projects requiring large platform size.

Depending on the required loading capacity and platform length, it can be used as a single or a twin mast arrangement. SC8000 moves workers, tools and building materials to the desired height at a single lift.

Rack and pinion driven mast climbing work platform saves time and money at work sites.

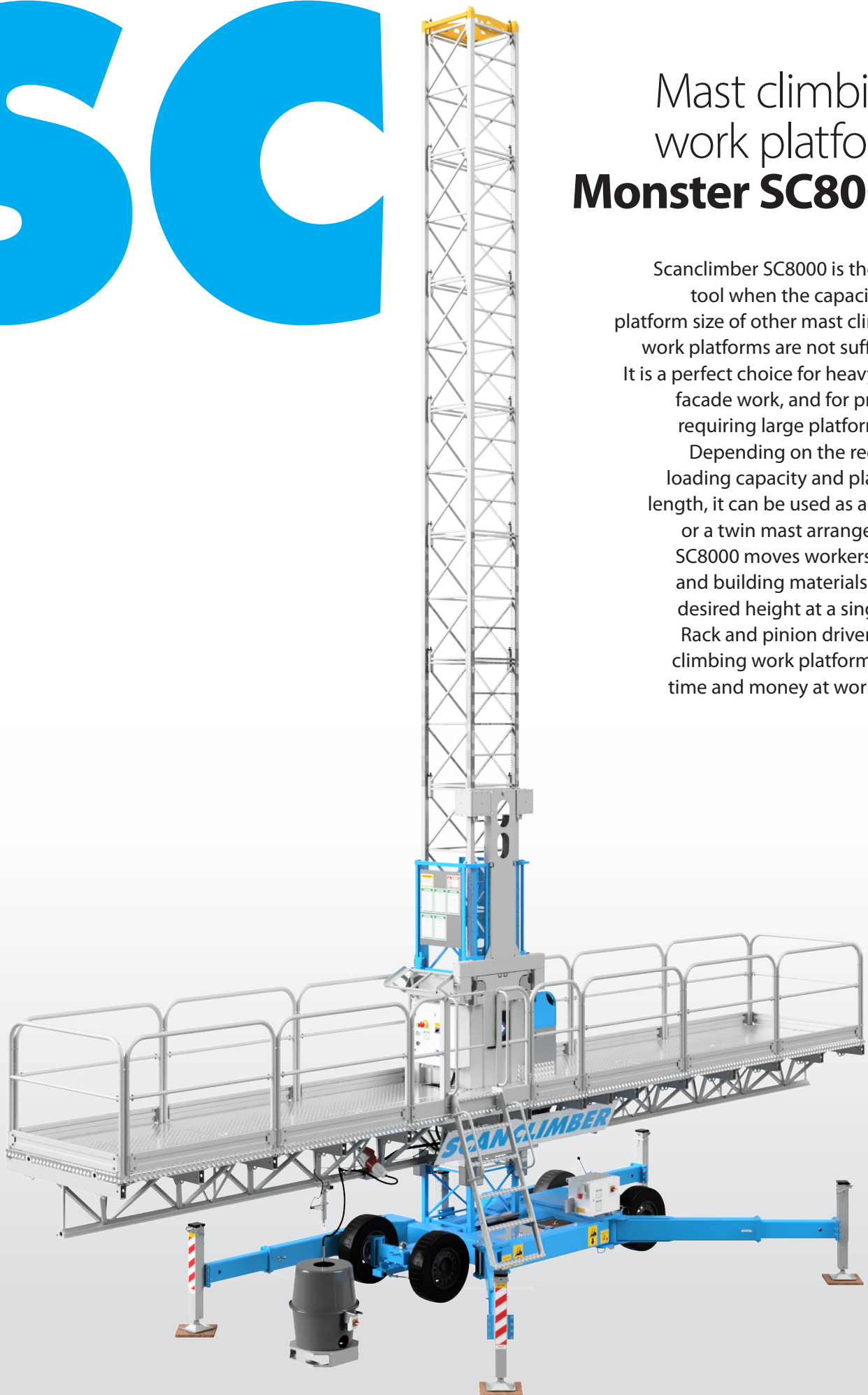

SCANCLIMBER

PART OF ALIMAK GROUP

Monster SC8000

Improved productivity and ergonomics for heavy-duty tasks

RACK AND PINION DRIVEN SC8000 mast climbing work platform is a robust lifting machine as well as a working platform in one convenient package. You can lift materials and workers to the desired working height safely and conveniently at the same time. It is ideal for heavy-duty facade work, and for projects requiring extra-large platform size. A mast climbing work platform saves time and money at work sites.

WORK PRODUCTIVITY can be easily improved by one-third with a mast climbing work platform. Two people working on the platform can achieve the same results as four workers working on traditional scaffoldings. The mast climbing work platform reduces and speeds up considerably the time-consuming up and down travel during working days.

THE MAST CLIMBING WORK PLATFORM is a perfect platform for all facade renovation work and different installations. Work can always be conducted at an ergonomically ideal height. If necessary, the platform can be protected from wind and rain, and even be heated, which guarantees continuation of work also during cold seasons. A mast climbing work platform is an economical and time-saving solution, for example, in the following work:

- Facade renovations
- Chimney repair & maintenance
- Bricklaying and tiling
- Painting and plastering
- Balcony renovations
- Window installations
- Dock work.

Stable and secure platform guarantees loading capacity of up to 8000 kg

THE LOADING CAPACITY is 4500 kg for a single mast SC8000 and 8000 kg for a twin mast arrangement. With a full 17-meter platform a single mast machine is able to lift 2800 kg. Using a twin mast arrangement the platform can be extended up to 46 meters, the lifting capacity thus being 1000 kg. Swivelling telescopic outriggers of the wheel chassis allow the chassis' support points to be spread far apart. This enables great free-standing heights. A maximum free-standing height of a SC8000 mast climbing work platform is 19 meters. When anchored with standard parts at constant intervals the mast can reach up to a height of 150 meters. Special mast ties allow even greater heights with no limits.

SURROUNDING RAILINGS of Scanclimber mast climbing work platforms naturally increase safety at work. The platform is also equipped with fastening points for safety harnesses. These safety features effectively minimise injuries incurred by slipping or falling at work site. All Scanclimber mast climbers are safety-approved worldwide. A strong safety brake provides additional level of protection.

THE MODULAR DESIGN enables the use of same parts and components with different Scanclimber models. The platform is easy and quick to erect and assemble manually, and to transfer to a new location, when necessary. The mast section weighs 82 kg and the platform module around 130 kg. The material of the mast and platform is hot-dip galvanised steel. The platform floor is made of ridged aluminum sheet. Since the mast climber can be dismantled into modules, it is easy to store and requires little space.

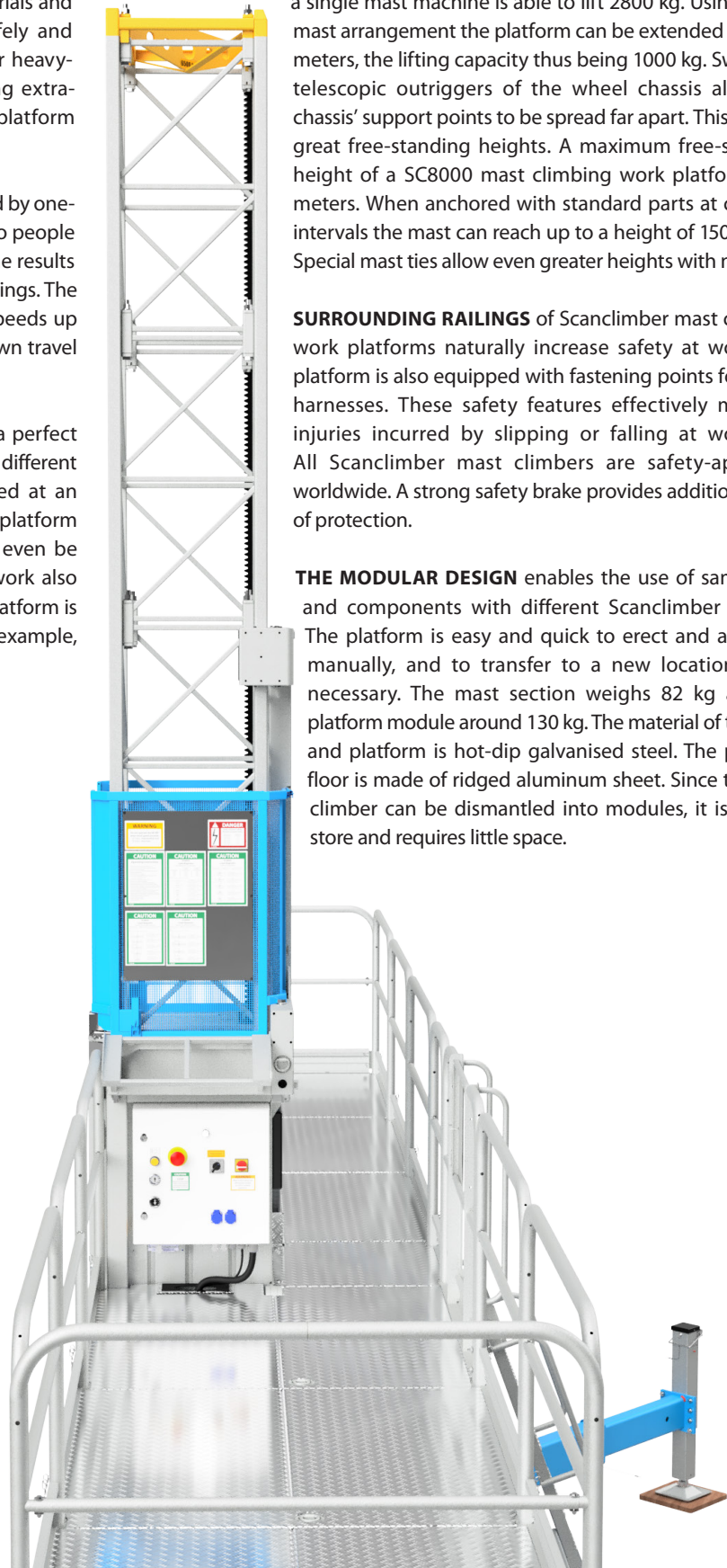

Cable Anti-Snagging Device

MCWP EQUIPPED WITH AN ANTI-SNAGGING DEVICE improves the operational safety. Cables are constantly in motion and must withstand high tensile stresses during operations. Anti-Snagging device automatically stops the MCWP in case of cable entanglement without causing any harm to the cable.

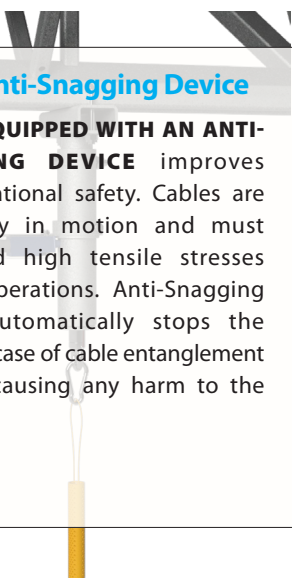

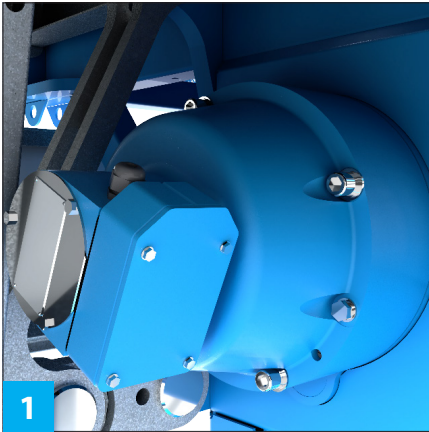

1

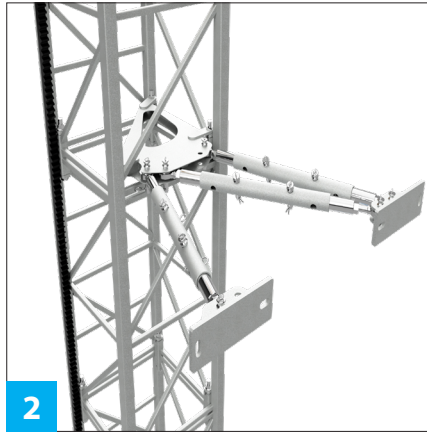

2



3

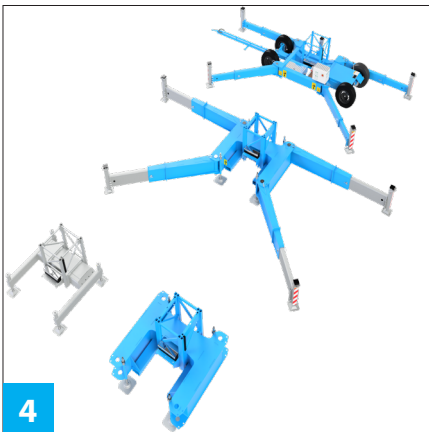

4



5



6

Details

Safety brake

1 A **MECHANICAL**, centrifugal safety brake is a standard feature on all Scanclimber mast climbing work platforms. It improves user safety, increases operational reliability and reduces the risk of breakdown. The safety brake is protected from dust and dirt.

Mast tie

2 A **ROBUST PLATFORM** requires sturdy anchoring. SC8000's mast is mounted on a vertical surface with Maxi ties, which are considerably stronger and sturdier compared to traditional mast ties. An extra-strong mast tie allows tying distance of up to 18 meters, which speeds up the mast erection and yields savings.

Twin masts

A **TWIN MAST ARRANGEMENT** makes SC8000 even more robust and allows the platform length to be nearly tripled from 16.9 meters to 46.2 meters. Also the maximum loading capacity can be nearly doubled, if necessary, from 4500 kg to 8000 kg.

Chassis

SC8000 is available with a wheel chassis or mini-chassis. An SC8000 on a wheel chassis can be moved around a work site with its own electric motor, or it can also be towed using towing bars. The wheel chassis has swivelling telescopic outriggers that can be adjusted in several positions to support the mast climbing work platform. The outriggers allow the machine standing on the wheel chassis to be erected without mast ties. With optimal outrigger positions the largest free-standing heights are: 19 m with a single arrangement and 18 m with a twin mast.

Extensions

WITH **ADJUSTABLE** extensions the platform width can be steplessly extended up to 6 meters. The extensions are available in four sizes: 2.6–6 m, 0–2.5 m, 0–1.8 m, and a brick laying extension. With these extensions you can also work behind or around different corners. Using a brick laying extension the working platform can be lowered 70 cm below the platform level, in which case the materials on the platform are at a suitable height for the bricklayer thus improving ergonomics at work.

SNAKE, the hinged platform system can be used with SC8000. Each of Snake's platform sections (up to 8 units) can be steplessly adjusted ± 45 degrees. The sections are available in two lengths: 1.5 m and 0.6 m. The platform moves like a snake in the horizontal plane forming into just about any shape. The platform can also be easily adjusted from the platform level during work. Snake is suitable for working on round, curved, cone-shaped and other varying wall surfaces.

Mast

THE MAST SECTION is completely hot-dip galvanised. Its height is 1.25 meters and it weighs 82 kg. The mast assembled from sections is supported on the wall at maximum intervals of 18 meters.

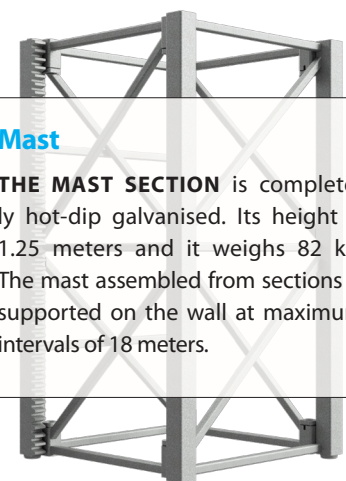

Technical Data

	Single mast SC8000	Twin mast SC8000
Max. platform length / loading capacity	4.1 m / 4500 kg 7.3 m / 4100 kg 10.5 m / 3700 kg 13.7 m / 3250 kg 16.9 m / 2800 kg	15.8 m / 8000 kg 20.6 m / 7800 kg 25.4 m / 7200 kg 30.2 m / 5600 kg 35.0 m / 4600 kg 40.6 m / 3600 kg 46.2 m / 1000 kg
Max. freestanding height		
- with extended outriggers on both side	9–19 m*	9–18 m*
- with extended outriggers on one side	9–15 m*	9–15 m*
Max. height with top tie	25 m	25 m
Max. height with mast tied	150 m (higher mast by request)	150 m (higher mast by request)
Distance between mast ties	18 m	18 m
Lifting speed	7.2 m / min	7.2 m / min
Mast section, hot-dip galvanised	1.25 m / 82 kg	1.25 m / 82 kg
Electric system		
- lifting motors	2x400 V/50 Hz/4 kW, 3 phase/32 A	4x400 V/50 Hz/4 kW, 3 phase/32 A
- drive motor	400 V/1.1 kW	2x400 V/1.1 kW
Safety devices		
- overspeed safety brake	◆	◆
- emergency stop and limit switches	◆	◆
- electromagnetic brake	◆	◆
- phase sequency relay	◆	◆
- residual current device	◆	◆

* depending on the platform length

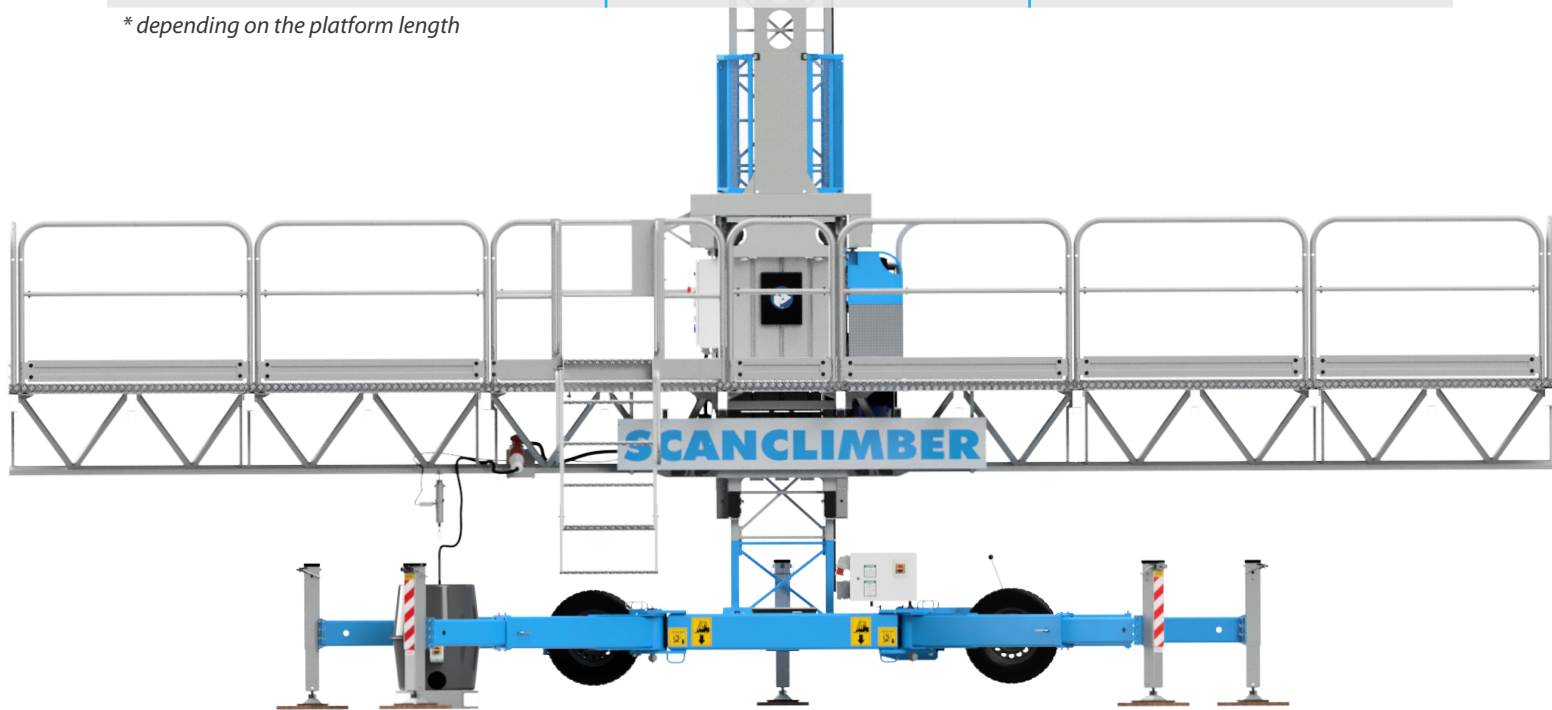

Scanclimber is a global leader in the design and manufacture of vertical access solutions for construction, renovation, and demolition projects globally. The company provides high quality mast climbing work platforms and custom vertical access solutions built on advanced rack and pinion technology. With a commitment to quality and innovation, Scanclimber continues to set new standards in the industry. Scanclimber is part of Alimak Group, which is headquartered in Stockholm, Sweden.

SCANCLIMBER

PART OF ALIMAK GROUP

Scanclimber Oy, Turkkirata 26, FI-33960 Pirkkala | www.scanclimber.com

Tel. +358 10 680 7000